

CI/SfB
Xt6
FEBRUARY 2018



Vista Engineering Limited

Windposts

CE

Engineered Strength



The Vista Windpost and Parapet Post range provides support to masonry panels subject to higher lateral loads without the need for extra columns or an increase in wall thickness.

As an architect, engineer or builder, you need to be sure the materials you choose are up to the job. All our windposts, parapet posts and spine posts can be produced to your specifications, based on design sheets that can be downloaded from our website. So you know they'll deliver the performance you demand, in the most extreme of environments.

Vista Engineering Ltd comply with CE marking regulations and are able to undertake welded fabrication work to Execution Class 2 of harmonised standard BS EN 1090-1:2009 +A1:2011. A copy of the Factory Production Control Certificate can be downloaded from vistaeng.co.uk/downloads

VEW1 Windposts

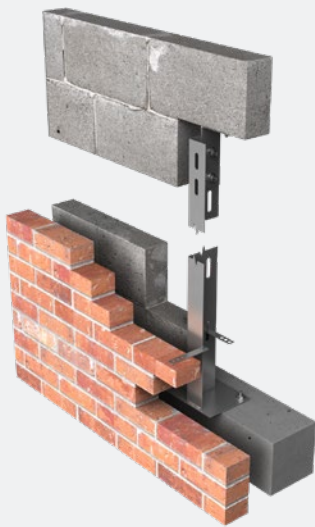

Additional strength and load resistance is created by embedding the inner leg of the **VEW1 Windpost** into the inner leaf joint.

VEW2 Windposts



Designed to sit in the cavity itself and tied to both inner and outer leaves, **VEW2 Windposts** are ideal for more lightly loaded walls.

VEW1 & VEW2 Parapet Posts

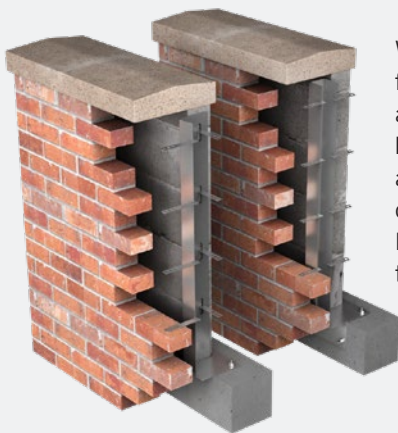

With no head fixings, **Vista VEW1** and **VEW2 Parapet Posts** are designed as propped cantilevers, using heavier base fixings to resist movement.

VEW3 Spine Posts



Sitting within the width of a single block, **VEW3 Spine Posts** add strength without ruining the 'fair faced' finish of internal walls.

VEW1 Windposts

VEW1 Windposts are positioned so that the longer leg is built into the inner leaf, with the return leg sitting in the cavity - a very strong arrangement for heavily loaded walls.

Introduction

The **Vista VEW1** range of windposts are of angle section where the inner leg 'A' of the post is built into the inner leaf with the return leg 'B' sitting in the cavity.

Vista VEW1 Windposts are generally used for heavily loaded conditions or for small cavities where the Vista VEW2 type post may not fit.

Vista WPTC

One-way windpost tie usually only required when the **Vista VEW1** is being used at a movement joint location or at an opening. Not supplied as standard please specify if required when ordering.

Vista WPT2

Two-way windpost ties usually supplied 200mm long. The ties can be supplied with a debonding sleeve for windposts being used at movement joint locations.

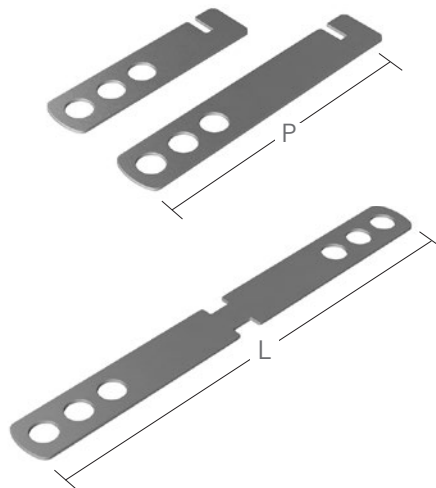
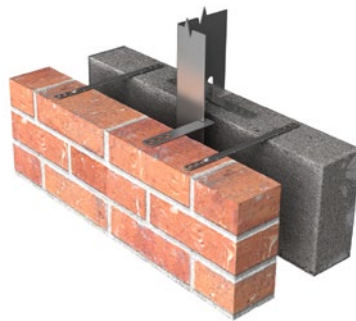
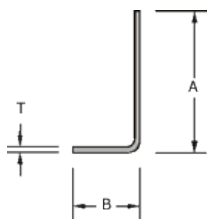

Vertical slots at the head connection allow for frame shrinkage up to +/- 24mm

The first slot positioned to suit coursing level. Slots at 225 mm centres thereafter.

VEW1 Windpost

VEW1 Windpost Connection Examples

Head fixed using **M12 M.D.Anchor** into concrete slab.



Base fixed using **M12 FBN II Anchor** into concrete slab.

Head fixed using **M12 H.S. Anchor** into R.H.S.



Base fixed using **M12 Isolated Setscrews** into steelwork.

Head fixed using **M12 Coachscrew** into timber wallplate.



Base fixed using **M12 FBN II Anchor** into concrete slab.

4 VEW2 Windposts

VEW2 Windposts

Sitting in the cavity of the wall itself and anchored at the head and base, VEW2 Windposts are generally used for lighter load conditions than the VEW1 type posts.

Introduction

The Vista VEW2 range of windposts are of channel section where the post sits in the cavity of the wall, they are generally used for lighter load conditions than the Vista VEW1 type posts.

The use of a Vista VEW2 Windpost is governed by the size of the cavity and the load to be supported i.e. it may not be possible to increase the section of the post and therefore its load capacity due to the size of the cavity. In the case of cast stone units the fixing options are increased as cast-in fixings may also be considered.

Minimum Channel Sections

T (mm)	"A"	"B"
4	35	20
5	35	25
6	40	35
8	55	50
10	90	80
12	90	80

Vista WPTC

The Vista WPTC one way tie is clipped to VEW2 edges to tie into both block and brick courses. When ordering, please specify projection 'P' from front of notch to tie end.

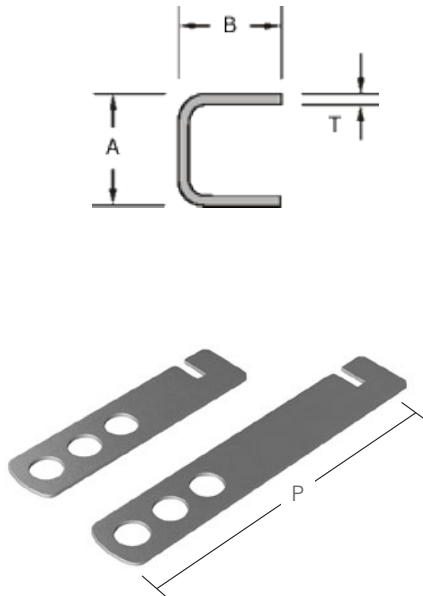

Vertical slots at the head connection allow for frame shrinkage up to +/- 24mm

The first slot positioned to suit coursing level. Slots at 225 mm centres thereafter.

VEW2 Windpost

VEW2 Windpost Connection Examples

Head fixed using M12 FBN II Anchor into concrete slab.



Base fixed using M12 FBN II Anchor into concrete slab.

Head fixed using M12 BSB Bolt into R.H.S.



Base fixed using M12 Isolated Setscrews into steelwork.

Head fixed using M12 Coachscrew into timber wallplate.



Base fixed using M12 FBN II Anchor into concrete slab.

VEW1&2 Parapet Posts

A range of shorter length posts for use in applications such as car park top level walling, with larger base fixings to resist the increased bending moment brought on by the lack of head fixing.

Introduction

Parapet and spandrel posts are designed as cantilevers and are available in both the Vista VEW1 and Vista VEW2 section types.

Larger base connections will be required to resist the 'bending moment' and careful consideration of the plate, fixings and base structure is required to ensure the post resists the applied loading.



Vista VEW1 Parapet Post Properties

The table on page 6 shows section properties, recommended resistance loads and design resistance loads for VEW1 Parapet Posts designed as cantilevers.

For further information on alternative Vista VEW1 Parapet Post sections and loadings, please contact Vista Engineering.

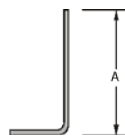

Vista VEW2 Parapet Post Properties

Page 6 also contains section properties, recommended load and design load figures for VEW2 Parapet Post sections when used as cantilevers.

For further information on alternative Vista VEW2 Parapet Post sections and loadings, please contact Vista Engineering.

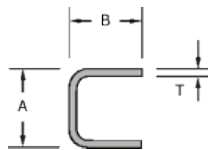

Base Plate Examples



Base fixed using M12 FBN II Anchor into concrete slab.



Base fixed using M12 Isolated Setscrews into steelwork.



Base fixed using M12 FBN II Anchor into concrete slab.

VEW3 Spine Posts

Spine posts are flat section posts designed to sit within the width of a masonry wall to preserve a 'fair faced' finish to both sides. They are anchored in same way as VEW1 and VEW2 posts.

Introduction

VEW3 Spine Posts add strength and stability to single leaf walls without protruding beyond the width of the blockwork. In this way, decorative wall surfaces and 'fair faced' finishes are possible without compromising on safety.

Although the width of VEW3 Spine Posts is limited by the width of the masonry (we recommend they sit within the wall by at least 10mm either side), the thickness of the post itself can be increased to add to its load capacity.



VEW3 Spine Post

Vista VEW3 Spine Post Properties

The tables on page 6 show section properties, recommended resistance loads and design resistance loads for VEW3 Spine Posts acting as simply supported beams.



For further information on alternative VEW3 Spine Post sections and loadings for posts designed as propped cantilevers, please contact Vista Engineering.

Vista WPT2

Spine posts are tied in using Vista WPT2 ties. These are usually supplied 200mm long and can be ordered with a debonding sleeve for spine posts being used at movement joint locations.

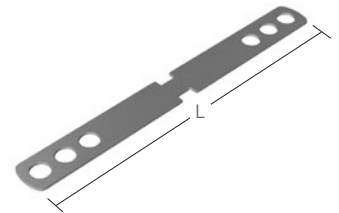

VEW3 Spine Post Connection Examples

Head fixed using M12 M.D. Anchor into concrete slab.



Base fixed using M12 FBN II Anchor into concrete slab.

Head fixed using M12 H.S. Anchor into R.H.S.



Base fixed using M12 Isolated Setscrews into steelwork.

Head fixed using M12 Coachscrew into timber wallplate.



Base fixed using M12 FBN II Anchor into concrete slab.

PERFORMANCE TABLES

Windposts are designed as simply supported beams with a maximum design strength of 230N/mm² and a maximum deflection of span/360. Design resistances should be compared with factored loads. Recommended loads include a variance factor of 1.5

VIEW1 WINDPOSTS

Windpost Section Size	Recommended resistance (UDL) kN per post							
	2.5m	3m	3.5m	4m	4.5m	5m	5.5m	6m
125 x 70 x 4	5.55	4.30	3.45	2.80	2.30	1.95		
140 x 70 x 4	7.20	5.55	4.45	3.65	3.05	2.55	2.15	
130 x 70 x 6	9.20	7.20	5.75	4.70	3.90	3.25	2.75	
150 x 70 x 5	10.50	8.25	6.70	5.50	4.55	3.90	3.30	
150 x 70 x 6	12.50	9.80	7.90	6.55	5.50	4.60	3.95	3.35
170 x 70 x 5	13.50	10.75	8.75	7.30	6.10	5.20	4.50	3.90
150 x 80 x 8	16.50	15.30	12.20	9.90	8.10	6.80	5.70	4.80
185 x 70 x 6	16.50	15.50	12.60	10.45	8.85	7.50	6.50	5.65
170 x 80 x 8	16.50	17.30	14.20	11.75	10.00	8.50	7.30	6.30
180 x 80 x 8	16.50	19.70	16.10	13.40	11.30	9.60	8.30	7.30

Bold figures indicate resistance limited by tie capacity.

VIEW1 WINDPOSTS

Windposts Section Size	Design resistance (UDL) kN per post							
	2.5m	3m	3.5m	4m	4.5m	5m	5.5m	6m
125 x 70 x 4	8.33	6.45	5.18	4.20	3.45	2.93		
140 x 70 x 4	10.80	8.33	6.68	5.48	4.58	3.83	3.23	
130 x 70 x 6	13.80	10.80	8.63	7.05	5.85	4.88	4.13	
150 x 70 x 5	15.75	12.38	10.05	8.25	6.83	5.85	4.95	
150 x 70 x 6	18.75	14.70	11.85	9.83	8.25	6.90	5.93	5.03
170 x 70 x 5	20.25	16.13	13.13	10.95	9.15	7.80	6.75	5.85
150 x 80 x 8	24.75	22.95	18.30	14.85	12.15	10.20	8.55	7.20
185 x 70 x 6	24.75	23.25	18.90	15.68	13.28	11.25	9.75	8.48
170 x 80 x 8	24.75	25.95	21.30	17.63	15.00	12.75	10.95	9.45
180 x 80 x 8	24.75	29.55	24.15	20.10	16.95	14.40	12.45	10.95

Bold figures indicate resistance limited by tie capacity.

VIEW2 WINDPOSTS

Winpost Section Size	Recommended resistance (UDL) kN per post							
	2.5m	3m	3.5m	4m	4.5m	5m	5.5m	6m
65 x 60 x 4	3.25	2.30	1.74	1.35				
65 x 60 x 5	3.95	2.80	2.10	1.60				
75 x 60 x 4	4.30	3.15	2.35	1.85				
75 x 60 x 5	5.40	3.86	2.90	2.25	1.75			
85 x 60 x 4	5.45	4.05	3.10	2.40	1.95			
85 x 60 x 5	6.95	5.09	3.80	2.95	2.35	1.90		
95 x 60 x 5	8.60	6.35	4.85	3.80	3.05	2.45	2.05	
105 x 60 x 5	10.30	7.75	6.00	4.75	3.80	3.10	2.55	2.15
105 x 60 x 6	11.10	9.05	7.00	5.50	4.40	3.60	3.00	2.50
115 x 60 x 8	11.10	13.30	10.60	8.50	6.85	5.60	4.65	3.90

Bold figures indicate resistance limited by tie capacity / ties required at reduced vertical centres.

VIEW2 WINDPOSTS

Windposts Section Size	Design resistance (UDL) kN per post							
	2.5m	3m	3.5m	4m	4.5m	5m	5.5m	6m
65 x 60 x 4	4.88	3.45	2.61	2.03				
65 x 60 x 5	5.93	4.20	3.15	2.40				
75 x 60 x 4	6.45	4.73	3.53	2.78				
75 x 60 x 5	8.10	5.79	4.35	3.38	2.63			
85 x 60 x 4	8.18	6.08	4.65	3.60	2.93			
85 x 60 x 5	10.43	7.64	5.70	4.43	3.53	2.85		
95 x 60 x 5	12.90	9.53	7.28	5.70	4.58	3.68	3.08	
105 x 60 x 5	15.45	11.63	9.00	7.13	5.70	4.65	3.83	3.23
105 x 60 x 6	16.65	13.58	10.50	8.25	6.60	5.40	4.50	3.75
115 x 60 x 8	16.65	19.95	15.90	12.75	10.28	8.40	6.98	5.85

Bold figures indicate resistance limited by tie capacity / ties required at reduced vertical centres.

VIEW1 PARAPET POSTS

Parapet Posts Section Size	Recommended resistance (UDL) kN per post						
	0.0m	1m	1.2m	1.4m	1.6m	1.8m	2m
125 x 70 x 4	4.50	4.50	3.80	2.95	2.35	2.00	1.75
140 x 70 x 4	4.50	5.60	4.70	4.00	3.10	2.60	2.25
130 x 70 x 6	4.50	6.00	6.10	5.10	3.90	3.30	2.90
150 x 70 x 5	4.50	6.00	6.50	5.60	4.85	3.80	3.20
150 x 70 x 6	4.50	6.00	7.50	6.90	5.70	4.50	3.95
170 x 70 x 5	4.50	6.00	7.50	7.00	6.10	5.40	4.35
150 x 80 x 8	4.50	6.00	7.50	9.00	7.80	6.00	5.30
185 x 70 x 6	4.50	6.00	7.50	9.00	9.00	8.00	6.50
170 x 80 x 8	4.50	6.00	7.50	9.00	10.40	8.70	7.10
180 x 80 x 8	4.50	6.00	7.50	9.00	10.50	10.20	8.30

Bold figures indicate resistance limited by tie capacity.

VIEW1 PARAPET POSTS

Parapet Posts Section Size	Design resistance (UDL) kN per post						
	0.8m	1m	1.2m	1.4m	1.6m	1.8m	2m
125 x 70 x 4	6.75	6.75	5.70	4.43	3.53	3.00	2.63
140 x 70 x 4	6.75	8.40	7.05	6.00	4.65	3.90	3.38
130 x 70 x 6	6.75	9.00	9.15	7.65	5.85	4.95	4.35
150 x 70 x 5	6.75	9.00	9.75	8.40	7.28	5.70	4.80
150 x 70 x 6	6.75	9.00	11.25	10.35	8.55	6.75	5.93
170 x 70 x 5	6.75	9.00	11.25	10.50	9.15	8.10	6.53
150 x 80 x 8	6.75	9.00	11.25	13.50	11.70	9.00	7.95
185 x 70 x 6	6.75	9.00	11.25	13.50	13.50	12.00	9.75
170 x 80 x 8	6.75	9.00	11.25	13.50	15.60	13.05	10.65
180 x 80 x 8	6.75	9.00	11.25	13.50	15.75	15.30	12.45

Bold figures indicate resistance limited by tie capacity.

VIEW2 PARAPET POSTS

Parapet Posts Section Size	Recommended resistance (UDL) kN per post						
	0.8 m	1 m	1.2 m	1.4m	1.6m	.8 m	2 m
65 x 60 x 4	3.90	2.95	2.30	1.85	1.50	1.25	1.05
65 x 60 x 5	4.50	3.85	2.95	2.35	1.90	1.55	1.30
75 x 60 x 4	4.50	3.70	2.90	2.35	1.95	1.60	1.35
75 x 60 x 5	4.50	4.85	3.80	3.05	2.50	2.05	1.70
85 x 60 x 4	4.50	4.50	3.60	2.90	2.40	2.00	1.75
85 x 60 x 5	4.50	6.00	4.70	3.80	3.15	2.60	2.20
95 x 60 x 5	4.50	6.00	5.60	4.60	3.80	3.20	2.70

Bold figures indicate resistance limited by tie capacity / ties required at reduced vertical centres.

VIEW2 PARAPET POSTS

Parapet Posts Section Size	Design resistance (UDL) kN per post						
	0.8m	1 m	1.2m	1.4m	1.6m	1.8m	2m
65 x 60 x 4	5.85	4.43	3.45	2.78	2.25	1.88	1.58
65 x 60 x 5	6.75	5.78	4.43	3.53	2.85	2.33	1.95
75 x 60 x 4	6.75	5.55	4.35	3.53	2.93	2.40	2.03
75 x 60 x 5	6.75	7.28	5.70	4.58	3.75	3.08	2.55
85 x 60 x 4	6.75	6.75	5.40	4.35	3.60	3.00	2.63
85 x 60 x 5	6.75	9.00	7.05	5.70	4.73	3.90	3.30
95 x 60 x 5	6.75	9.00	8.40	6.90	5.70	4.80	4.05

Bold figures indicate resistance limited by tie capacity / ties required at reduced vertical centres.

VIEW3 SPINE POSTS

Windpost Section Size	Recommended resistance (UDL) kN per post							
	2.5m	3m	3.5m	4m	4.5m	5m	5.5m	6m
90 x 8	3.00	2.20	1.65					
100 x 8	3.95	2.90	2.20	1.70	1.35			
110 x 8	5.00	3.75	2.90	2.25	1.80	1.45		
120 x 8	6.25	4.75	3.70	2.90	2.35	1.90	1.60	1.35

VIEW3 SPINE POSTS

Windpost Section Size	Design resistance (UDL) kN per post							
	2.5m	3m	3.5m	4m	4.5m	5m	5.5m	6m
90 x 8	4.50	3.30	2.48					
100 x 8	5.93	4.35	3.30	2.55	2.03			
110 x 8	7.50	5.63	4.35	3.38	2.70	2.18		
120 x 8	9.38	7.13	5.55	4.35	3.53	2.85	2.40	2.03

WINDPOST DESIGN SHEET **Service**

Vista undertake the design of the windpost and fixings required, based on your specifications set out on the design sheet below, and will produce all necessary drawings detailing the windpost length and connections for approval prior to manufacture.

Windpost Design Sheet	Company:	Vista Engineering Ltd Carr Brook Works Elnor Lane Whaley Bridge High Peak SK23 7JN T: 01663 736 700 F: 01663 736 710 sales@vistaeng.co.uk	
Contact Name:		Project:	
Contact Phone No.	E-Mail:	Date Required:	
Site Address		Order No.	

Post Type - Please tick relevant box

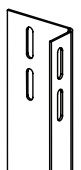

VEW1

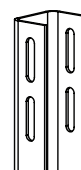

VEW2

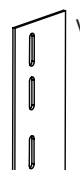

VEW3

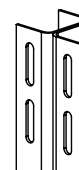

VEW4



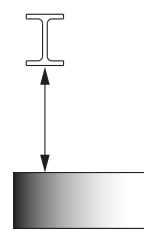

Qty Reqd = Section Size =

Structural Opening





mm



Top Connection - Please tick required top connection type and confirm sizes / dimensions requested

<input type="checkbox"/>  Steel Beam UB UB Section = <input style="width: 100px;" type="text"/> Offset "x" = <input style="width: 100px;" type="text"/>	<input type="checkbox"/>  Steel Beam RHS RHS Section = <input style="width: 100px;" type="text"/> Offset "x" = <input style="width: 100px;" type="text"/>	<input type="checkbox"/>  Concrete Slab Type = <input style="width: 100px;" type="text"/> Slab Depth "d" = <input style="width: 100px;" type="text"/>	<input type="checkbox"/>  Timber Wall Plate Size = <input style="width: 100px;" type="text"/> Offset "x" = <input style="width: 100px;" type="text"/>
---	---	---	---

Base Connection - Please tick required base connection type and confirm sizes / dimensions requested

<input type="checkbox"/>  Steel Beam UB UB Section = <input style="width: 100px;" type="text"/> Offset "x" = <input style="width: 100px;" type="text"/>	<input type="checkbox"/>  Steel Beam RHS RHS Section = <input style="width: 100px;" type="text"/> Offset "x" = <input style="width: 100px;" type="text"/>	<input type="checkbox"/>  Concrete Slab Depth "d" = <input style="width: 100px;" type="text"/>	<input type="checkbox"/>  Hollowcore Slab Depth "d" = <input style="width: 100px;" type="text"/>
---	---	---	---

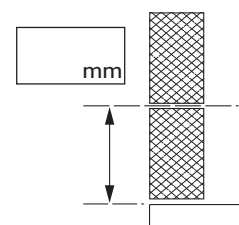
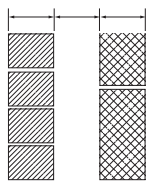
<p>First Tie Position</p> 	<p>Masonry Construction Dimensions</p> Brick = <input style="width: 50px;" type="text"/> mm Cavity = <input style="width: 50px;" type="text"/> mm Block = <input style="width: 50px;" type="text"/> mm 	<p>Additional Comments</p> <div style="border: 1px solid black; height: 100px; width: 100%;"></div>
Signature _____		Date _____

Available from:

All illustrations, technical information, descriptions, British and European Standards contained within this publication are intended for guidance only and shall not constitute a "sale by description". All information is provided correct at time of printing (February 2018). The Company pursues a policy of constant product development and information contained in this publication is therefore subject to change without notice. All dimensions given are nominal. Updates will not be issued automatically. The information is not intended to have any legal effect, whether by way of advice, representation or warranty (express or implied). We accept no liability whatsoever (to the extent permitted by law) if you place any reliance on this Publication and you must do so at your own risk.

Please contact our head office should you have any technical enquiries.

©Vista Engineering 2018.

Head Office

Vista Engineering Limited
Carr Brook Works,
Enlor Lane,
Whaley Bridge
High Peak SK23 7JN

Tel: Sales: +44 (0) 1663 736700
Fax: +44 (0) 1663 733232
web: www.vistaeng.co.uk
email: sales@vistaeng.co.uk

Scotland Office

Vista Engineering Limited
16 Baronald Street
Rutherglen
Glasgow G73 1AH

Tel: +44 (0) 141 613 3144
Fax: +44 (0) 141 613 3031

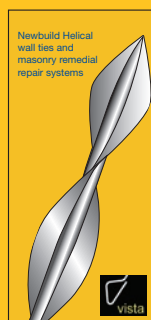

Contact us to enquire about our other product ranges or request a catalogue.

